

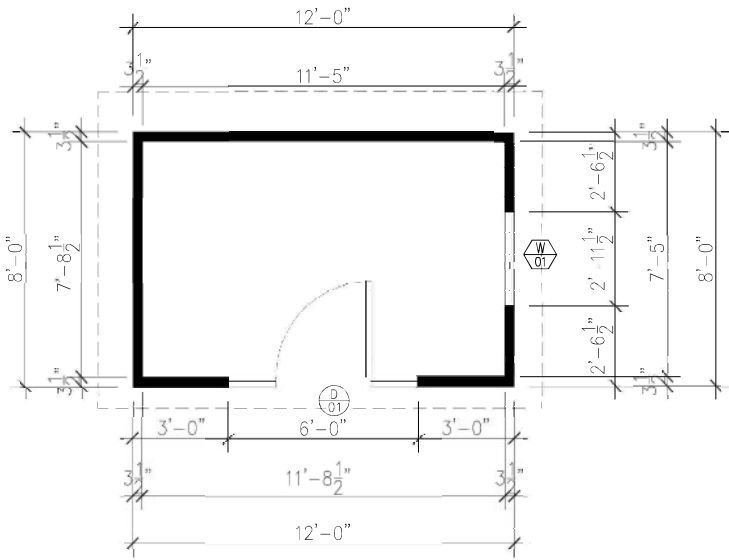

BEVERLY 0BD 0BA 96 SQ.FT.





1 GROUND FLOOR PLAN
Scale 1'=1/4

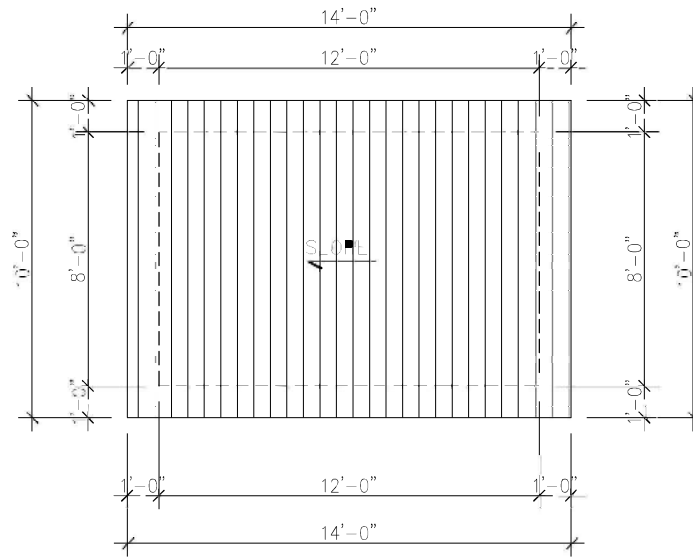

2 ROOF FLOOR PLAN
Scale 1'=1/4

AREA SCHEDULE	
ROOM	96,00 SF

DOORS SCHEDULE FOR					
DOOR MK	STRUCT. OPNG.		DOOR ROU. OPNG.		NOS. REQD.
	W	HT	W	HT	
D1	72"	80"	74"	82"	01

SCHEDULE OF WINDOWS					
WIND MK	STRUCT. OPNG.		WINDOW ROU. OPNG.		NOS. REQD.
	W	HT	W	HT	
W1	35,5"	35,5"	36"	36"	01

GROUND FLOOR PLAN

DESIGN: BEVERLY	ADDRESS	S.P.	ISSUE:	REV	DATE	DESCRIPTION	DRAWN	CHECKED
STAGED PLAN: PRELIMINARY	NOTE:	SCALE @ A3						
CLIENT:	USE FIGURED DIMENSIONS AT ALL TIMES; REFER ANY ENQUIRIES TO BUILDING CONTRACTOR. ALL DIMENSIONS TO BE VERIFIED ON SITE PRIOR TO CONSTRUCTION. ALL WORK TO COMPLY WITH LOCAL AUTHORITY REGULATIONS.	DWG NO: AR-001	LAND AREA:					

PRELIM - NOT FOR CONSTRUCTION



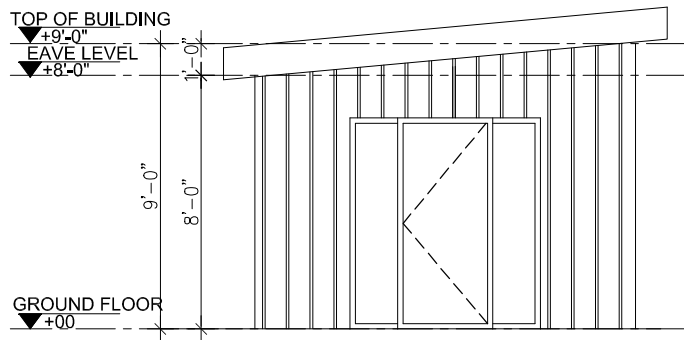

1 FRONT ELEVATION
Scale 1'=1/4"

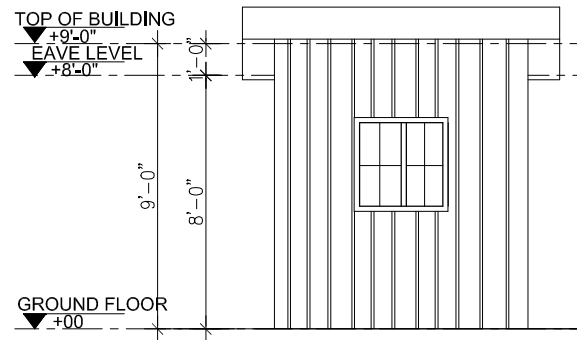

3 RIGHT SIDE ELEVATION
Scale 1'=1/4"

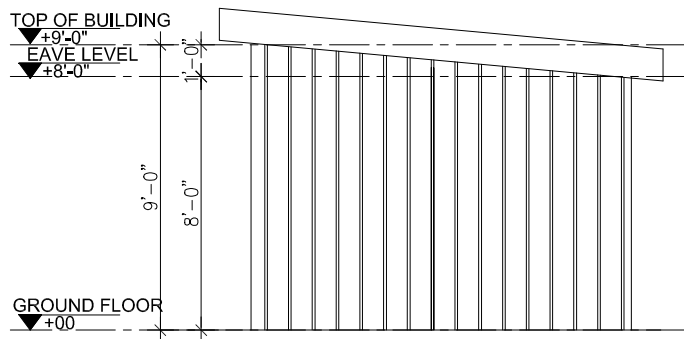

1 REAR ELEVATION
Scale 1'=1/4"

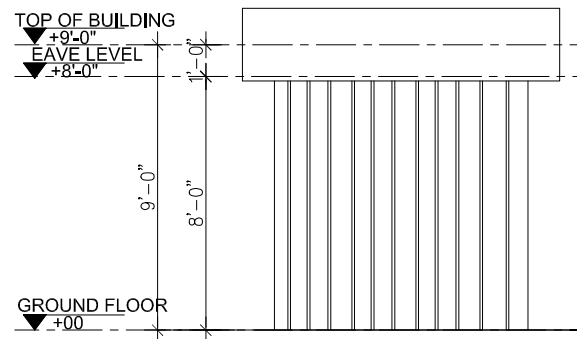

4 LEFT SIDE ELEVATION
Scale 1'=1/4"

ELEVATIONS

DESIGN:	ADDRESS	S.P.	ISSUE:	REV	DATE	DESCRIPTION	DRAWN	CHECKED
BEVERLY								
STAGED PLAN:	NOTE:	SCALE						
PRELIMINARY		@ A3						
CLIENT:	USE FIGURED DIMENSIONS AT ALL TIMES, REFER ANY ENQUIRIES TO BUILDING CONTRACTORS, ALL DIMENSIONS TO BE VERIFIED ON SITE PRIOR TO CONSTRUCTION, ALL WORK TO COMPLY WITH LOCAL AUTHORITY REGULATIONS.	DWG NO:	LAND AREA:					
		AR-002						

PRELIM - NOT FOR CONSTRUCTION



Drawings are not to scale. Colors and materials indicative only and are subject to change

Options available

- For any modifications to the plans, please contact us at info@welldone1kithomes.com

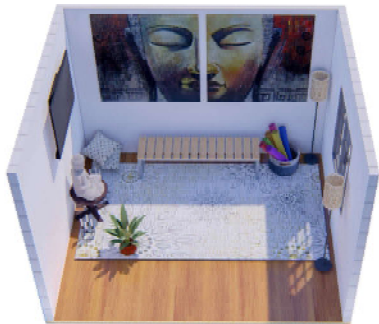

Yoga Room



Gaming Room

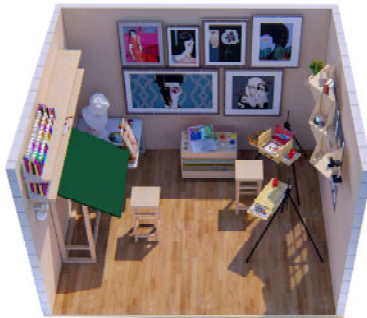

Please refer to the floor plans for recommendations on your interior layout.

Website : www.welldone1kithomes.com
Email : info@welldone1kithomes.com

DESIGN: Beverly	STAGED PLAN:: PRELIMINARY	ADDRESS: US	USE FIGURED DIMENSIONS AT ALL TIMES. REFER ANY ENQUIRES TO BUILDING CONTRACTOR. ALL DIMENSIONS TO BE VERIFIED ON SITE PRIOR TO CONSTRUCTION. ALL WORK TO COMPLY WITH LOCAL AUTHORITY REGULATIONS.
---------------------------	-------------------------------------	-----------------------	---

PRELIMINARY DESIGN-
Not for construction

